

SAFE-DRIVE™ POCKETGUIDE för installation

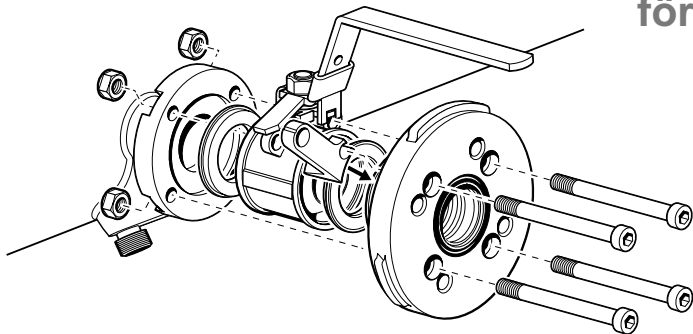

PR-23-SD
SDI2-23-SN2-XS
SDR2-23

IM-SV-SDI2INST-PG
Rev. 1.03

SÄKERHETSKRAV

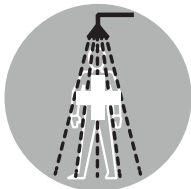

INSTALLATIONSUTRUSTNING

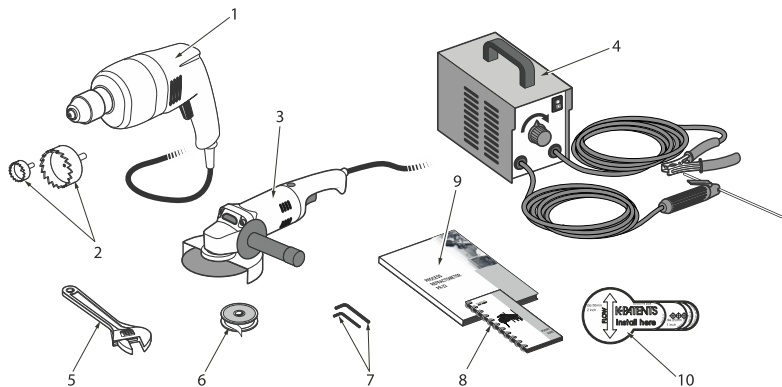

1. Borr
2. Hålsåg 1" och 2"
3. Vinkelslip
4. Svets
5. Skiftnyckel
6. Gängtejp
7. Insexnycklar 5 och 8 mm
8. Pocketguide
9. Instruktionsbok
10. Håltagningsguide

SENSORINSÄTTNINGSTRUSTNING

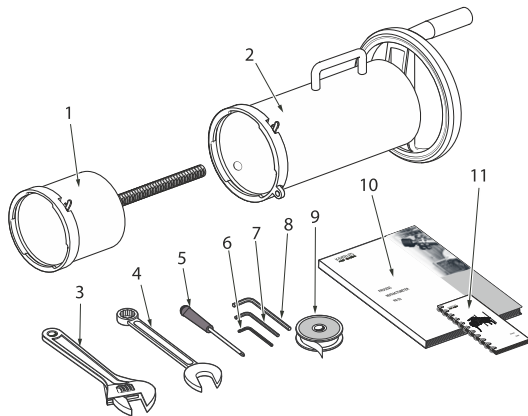

1. Utdragsdonets inre hölje
2. Utdragsdonets yttre hölje
3. Skiftnyckel
4. Kombinationsnyckel 19 mm / 3/4 in
5. Spårskruvmejsel
6. Insexnyckel 4 mm
7. Insexnyckel 5 mm
8. Insexnyckel 8 mm
9. Gängtejp
10. Instruktionsbok
11. Pocketguide

INSTALLATIONS- PLATS (horisontell)

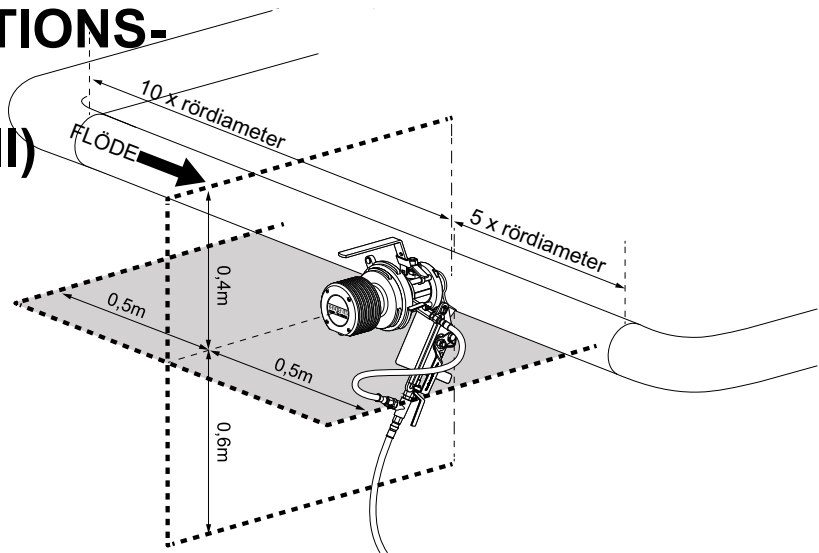

INSTALLATIONS- PLATS (vertikal)

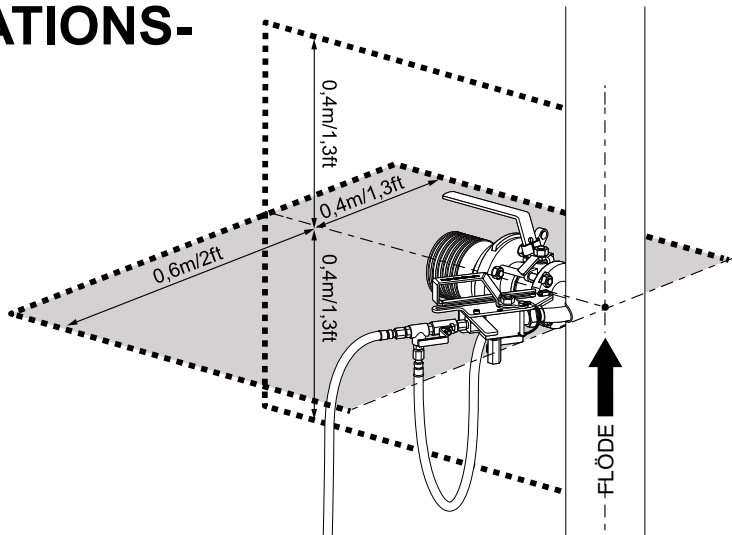

HÖG INSTALLATION

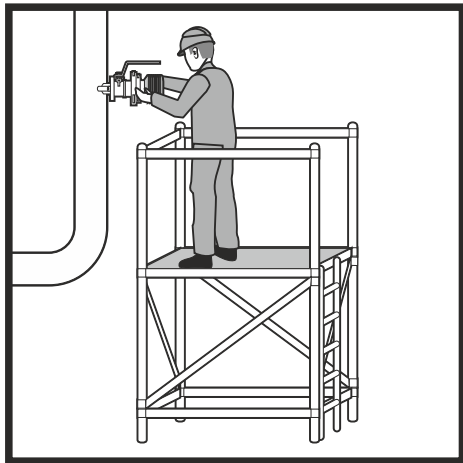
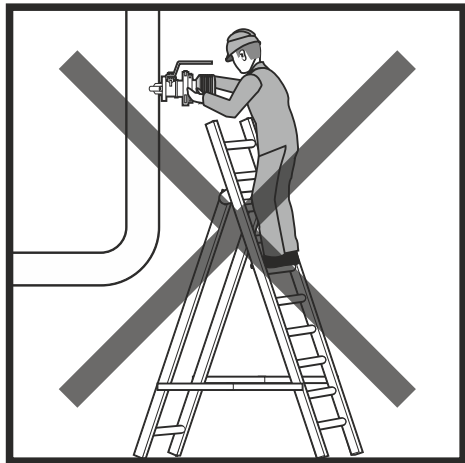

DEMONTERING

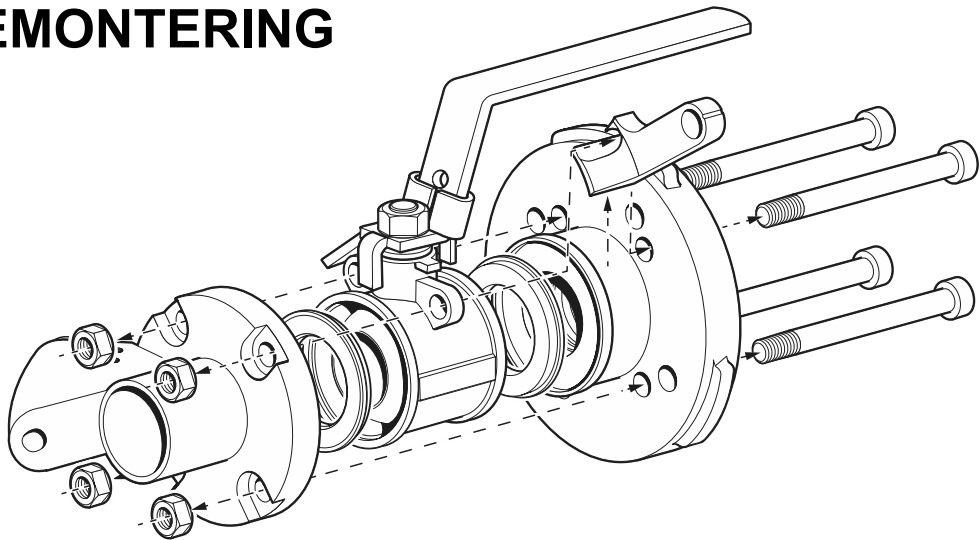

HÅLTAGNING (horisontell)

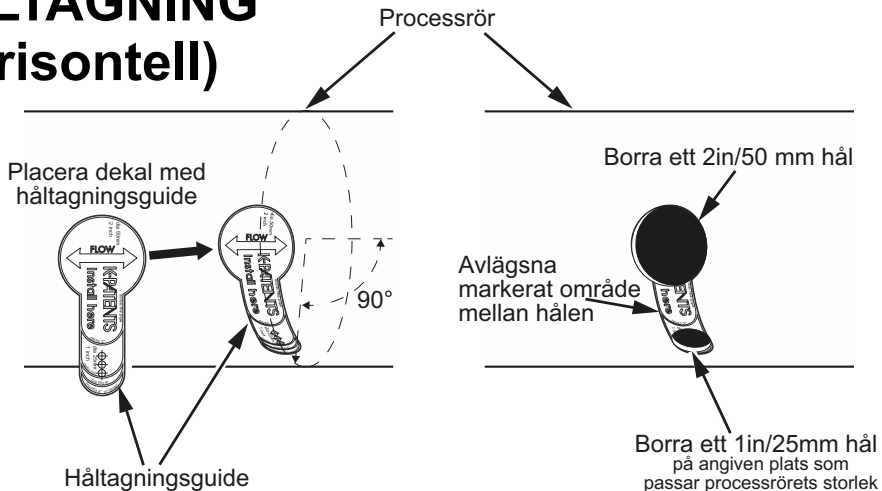

SVETSNING (horisontell)

Viktigt:
Avlägsna
munstycket
innan
svetsning

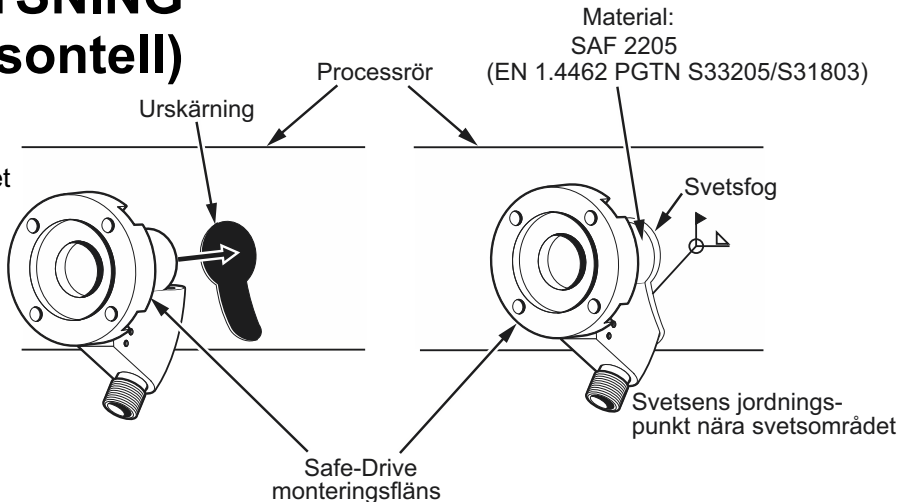

HÅLTAGNING (vertikal)

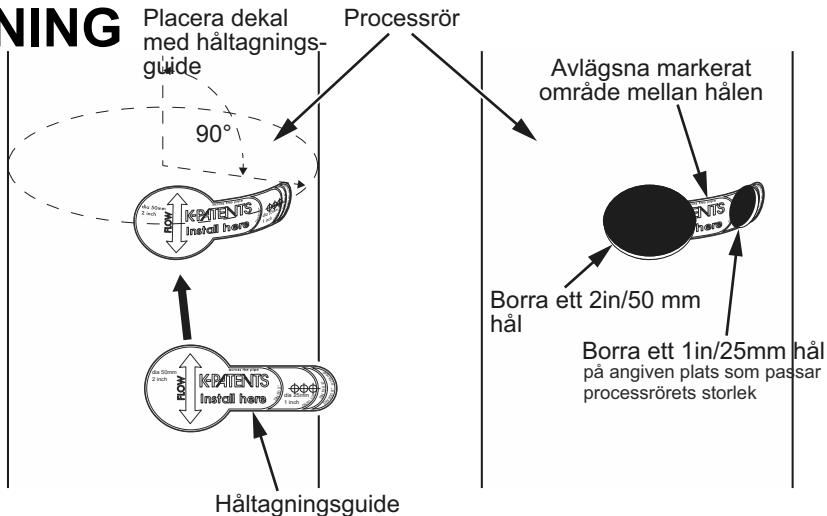

SVETSNING (vertikal)

Viktigt:
Avlägsna
munstycket
innan svetsning

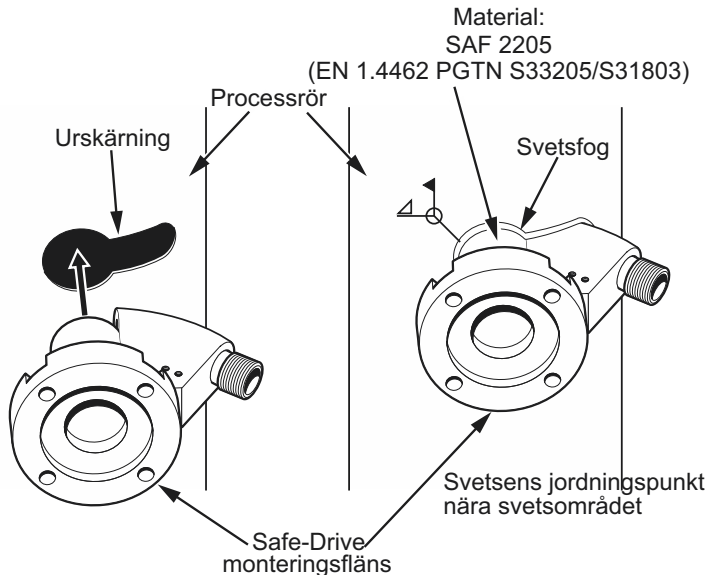

MONTERING (horisontell)

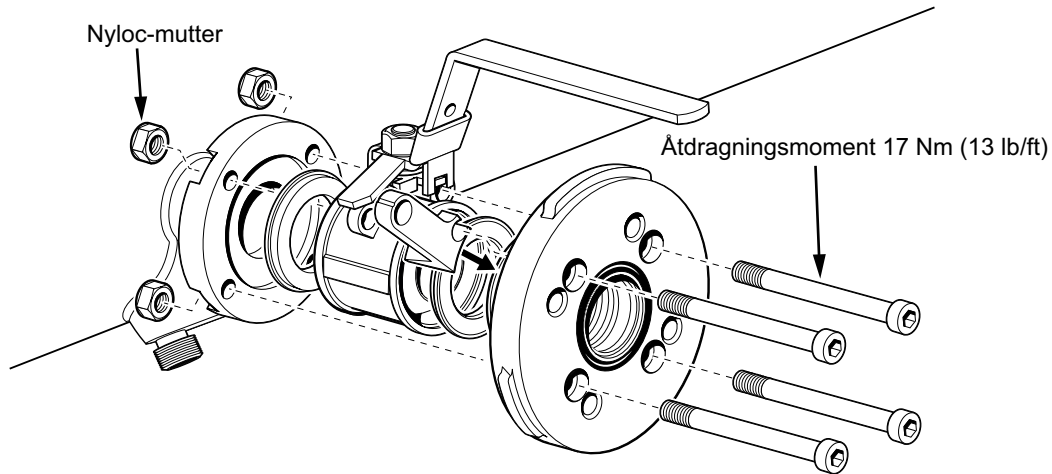

MONTERING (vertikal)

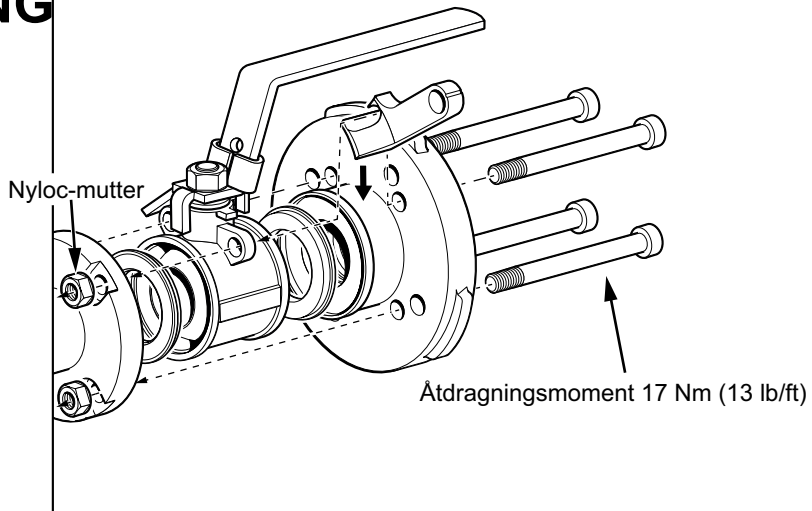

INSTALLATION AV ÅNGRÖR

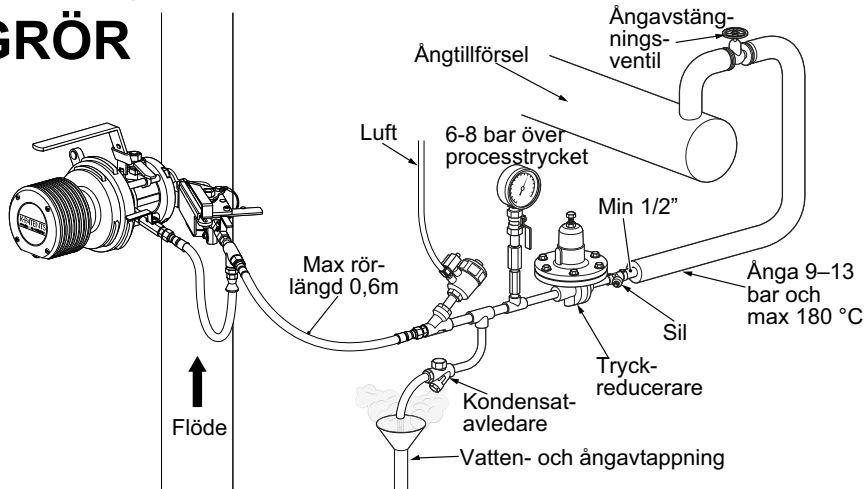

ÅNGRÖRS- ISOLERING

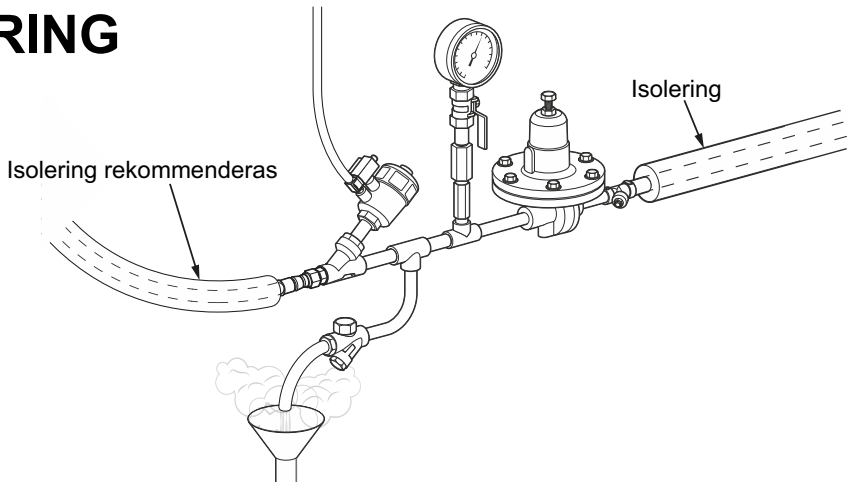

INSTALLATION AV HÖG- TRYCKS- VATTEN

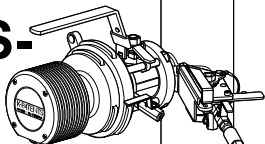

↑
Flöde

Max rör-
längd 0,6m

Manometer

Luft

Solenoidanslutningar till
transmitter DTR

Luft

Hett-
utblås-
nings-
vatten

Avstängnings-
kulventil 3/8"

Avstängnings-
kulventil 3/8"

Förkonditionering
till avlopp

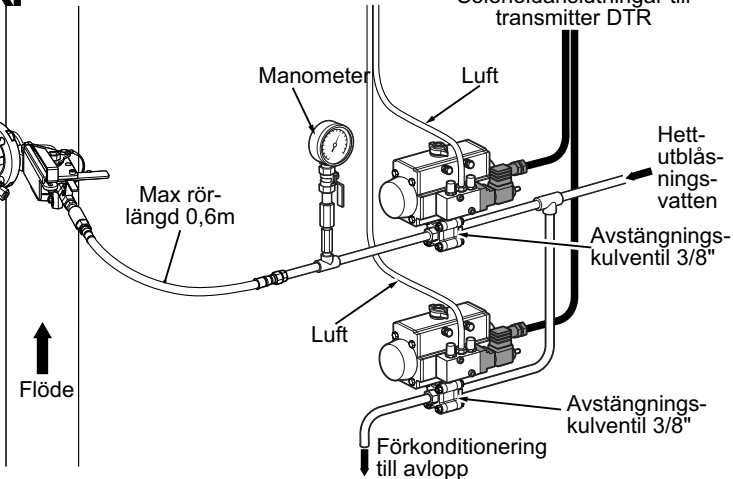

ISOLERING

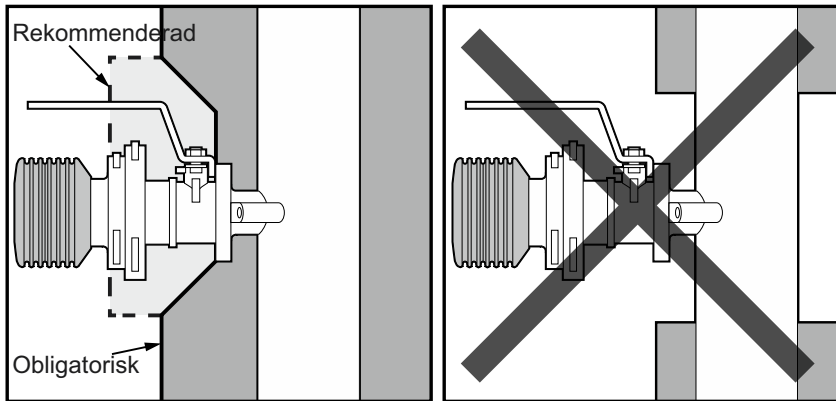

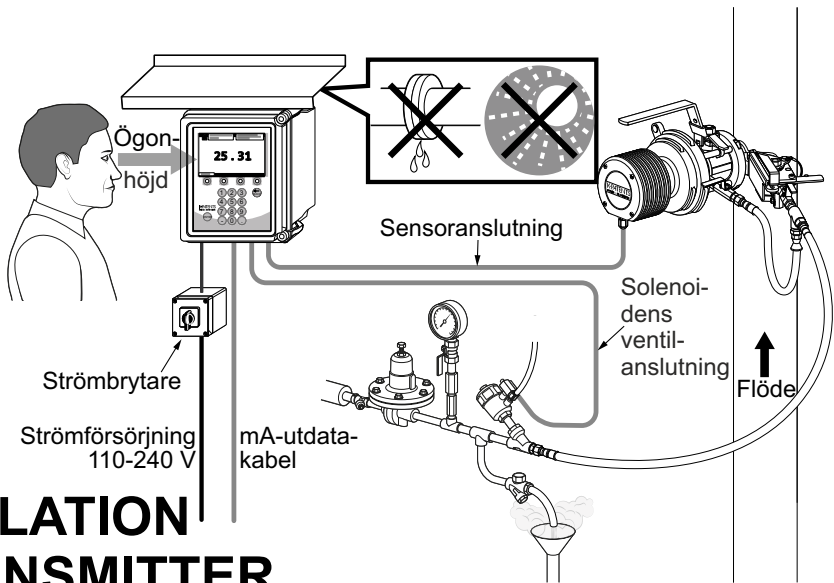

INSTALLATION AV TRANSMITTER



www.kpatents.com

K-PATENTS OY

P.O. Box 77
01511 Vantaa, Finland
Tel. +358 207 291 570
Fax +358 207 291 577
info@kpatents.com

K-PATENTS, INC.

1804 Centre Point Circle, Suite 106
Naperville IL 60653, USA
Tel. (630) 955 1545
Fax (630) 955 1585
info@kpatents-usa.com

K-PATENTS (SHANGHAI) CO., LTD

Room 1509, Tomson Commercial
Building, No. 710
Dongfang RD
Pudong District, Shanghai, China
Tel. +86 21 5087 0597/0598
Fax +86 21 5087 0598